

Weld together. The mount parts are welded with 2-3 short seams. Tubing and side support are welded with sealed seams. Everything should be centered in respect to the vertical tube. Fit black plastic end caps to vertical tube.

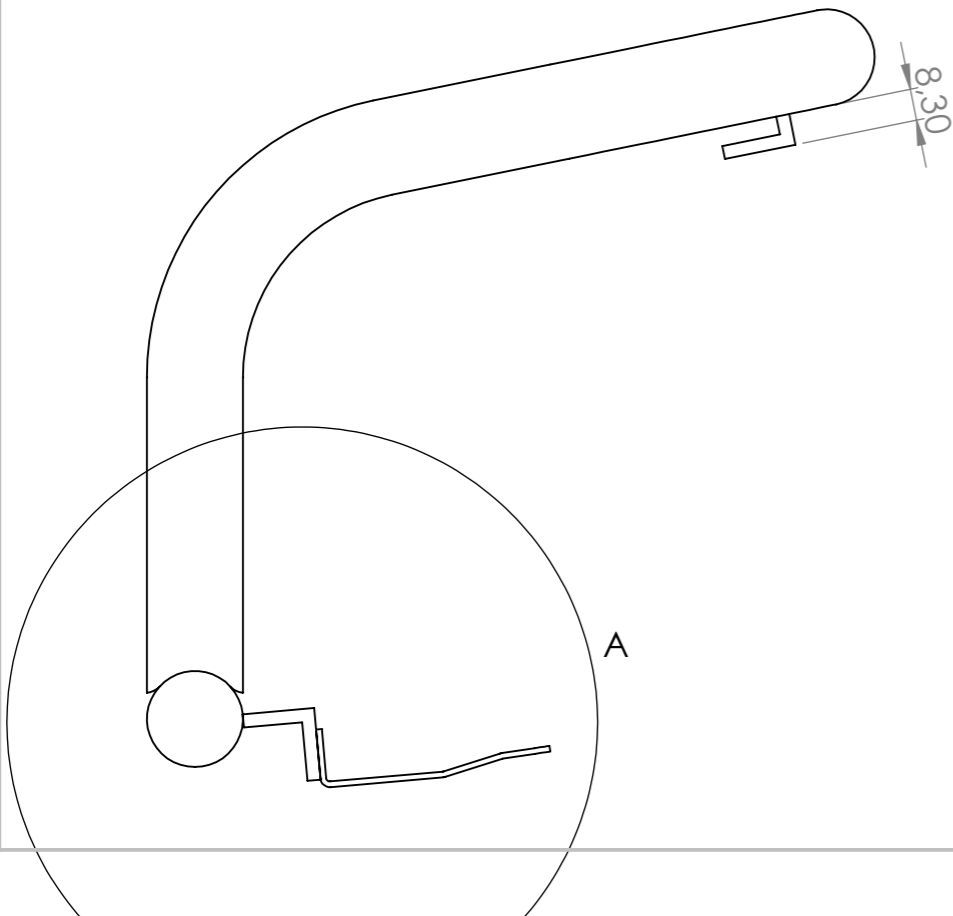

UNLESS OTHERWISE SPECIFIED: DIMENSIONS ARE IN MILLIMETERS SURFACE FINISH: TOLERANCES: LINEAR: ANGULAR:			FINISH:	DEBUR AND BREAK SHARP EDGES	DO NOT SCALE DRAWING	REVISION
					tomas_tjernberg@hotmail.com	
					TITLE:	
					DWG NO. JP-EX_tail_guard A3	
					SCALE:1:5	
					SHEET 1 OF 1	

	NAME	SIGNATURE	DATE
DRAWN	Tomas Tjernberg		
CHK'D			
APPV'D			
MFG			
Q.A			